



# Beaver Ballad



## Hello, my name is Elizabeth.

I'm the Artistic Director of Pitlochry Festival Theatre. While we can't welcome you to the theatre we've got stories and songs for making your own shows, in your own theatre at home, built in the garden or in your living room!

Using the illustrated guide of **How to Build Your Own Theatre** to make your stage, here is a **Beaver Ballad** to perform together. It has been written and illustrated by some more wonderful artists – Isobel McArthur, MJ McCarthy, Adrian Rees and Trudy Rees-Marklew. It includes instructions of how to create your very own Beaver costumes, and your Beaver home, as well as the words to a very special, new song – *To Be A Beaver* – all about the wonderful Beavers here on the River Tay in Perthshire, Scotland, near to Pitlochry Festival Theatre.

We can't wait to hear about how you've got on. We hope you enjoy making theatre and being Beavers at home!

Stay safe! Lots of love,

Elizabeth x



# 'To Be A Beaver'

★ Stan  
the Beaver

Beavers wear pyjamas because they are nocturnal or night time creatures

★ Don't forget your swimming costume!



★ Water Wings if you have them.

Morag the Beaver

★ Beavers have big flat tails  
Cut out a piece of cardboard, paint it and tie it to a belt, or ribbon!



ear - cut out 2

# How to Make a Beaver Mask

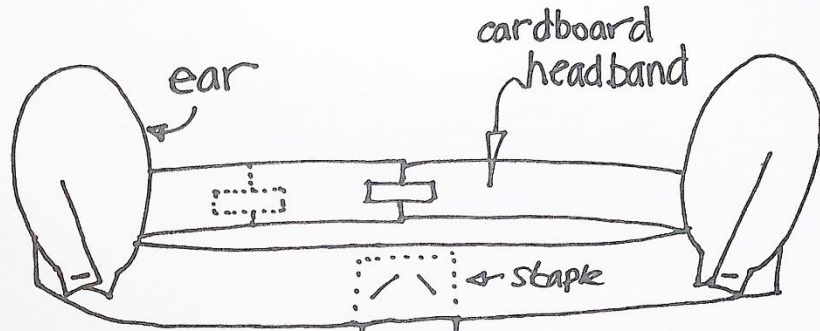
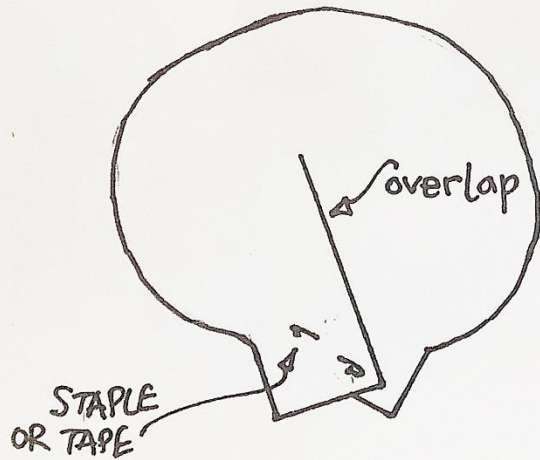
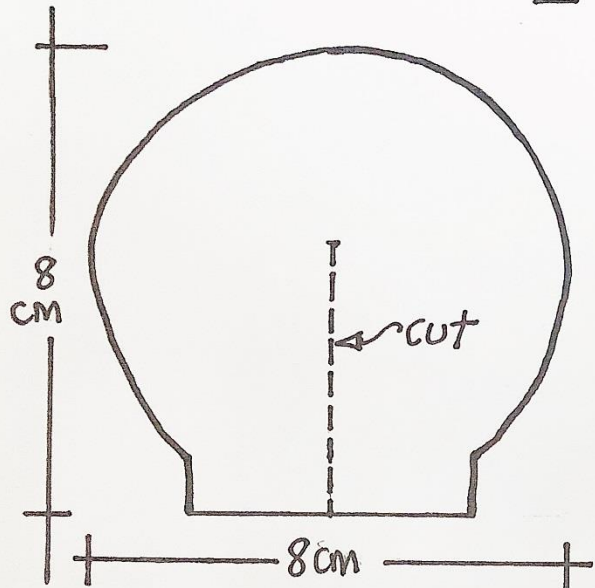

★  
Nose and  
teeth are  
cut from an  
egg box

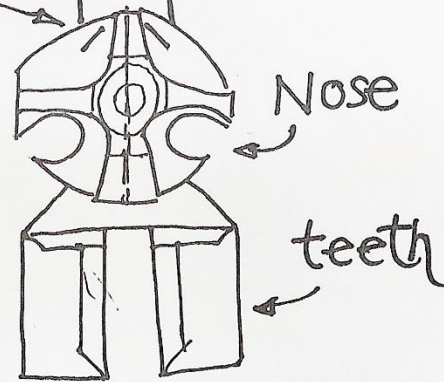

# How to Make a Beaver Headress

★ cut out the pieces needed from an egg box. You could get more than one nose-teeth section from one egg box

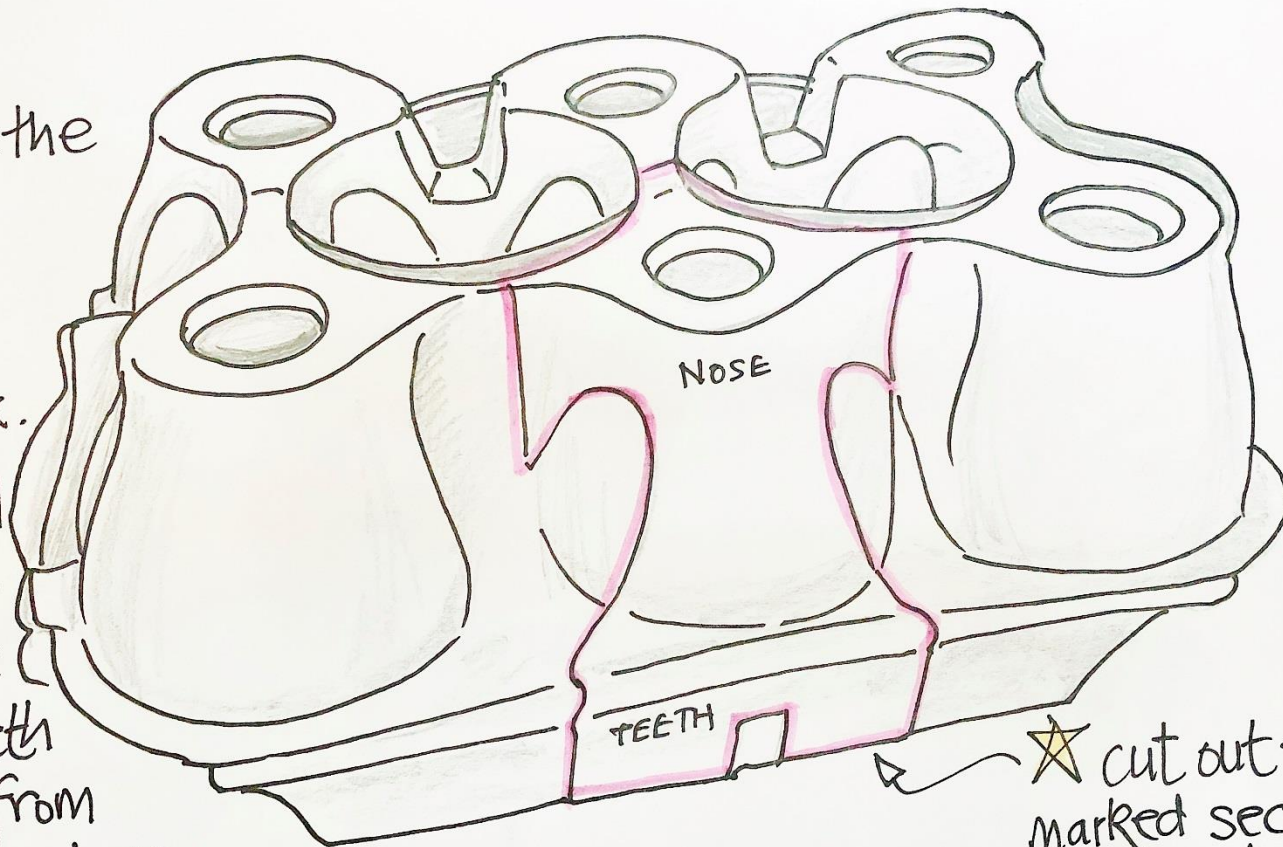

★ cut out the marked section of egg box



## The Beaver's Nose and Teeth

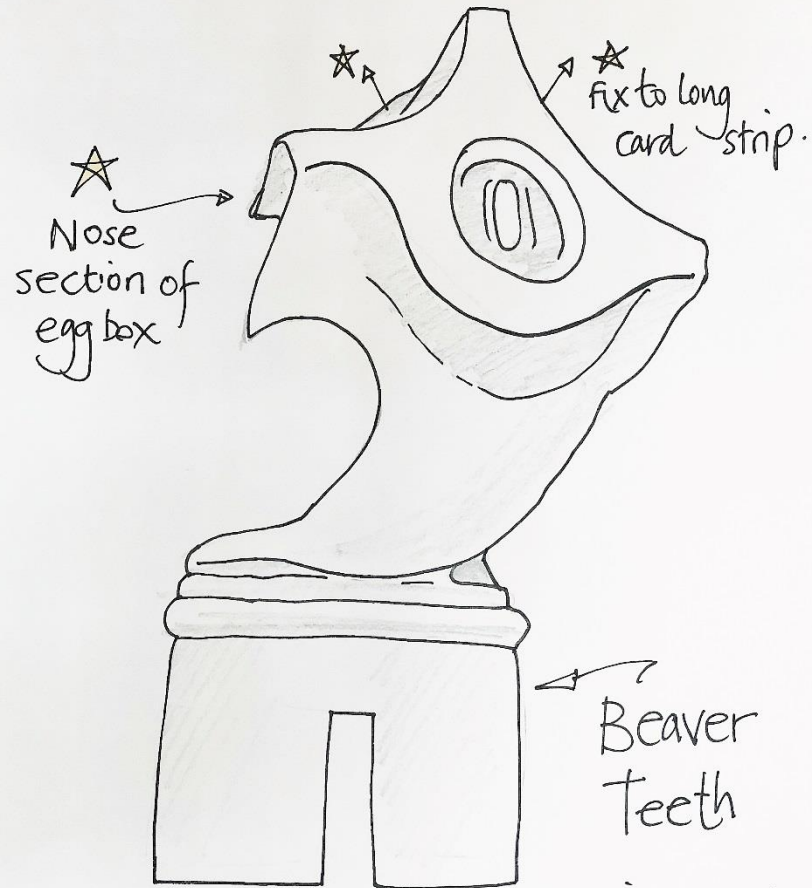

★ Don't forget that you can paint your head dress any colour you like!



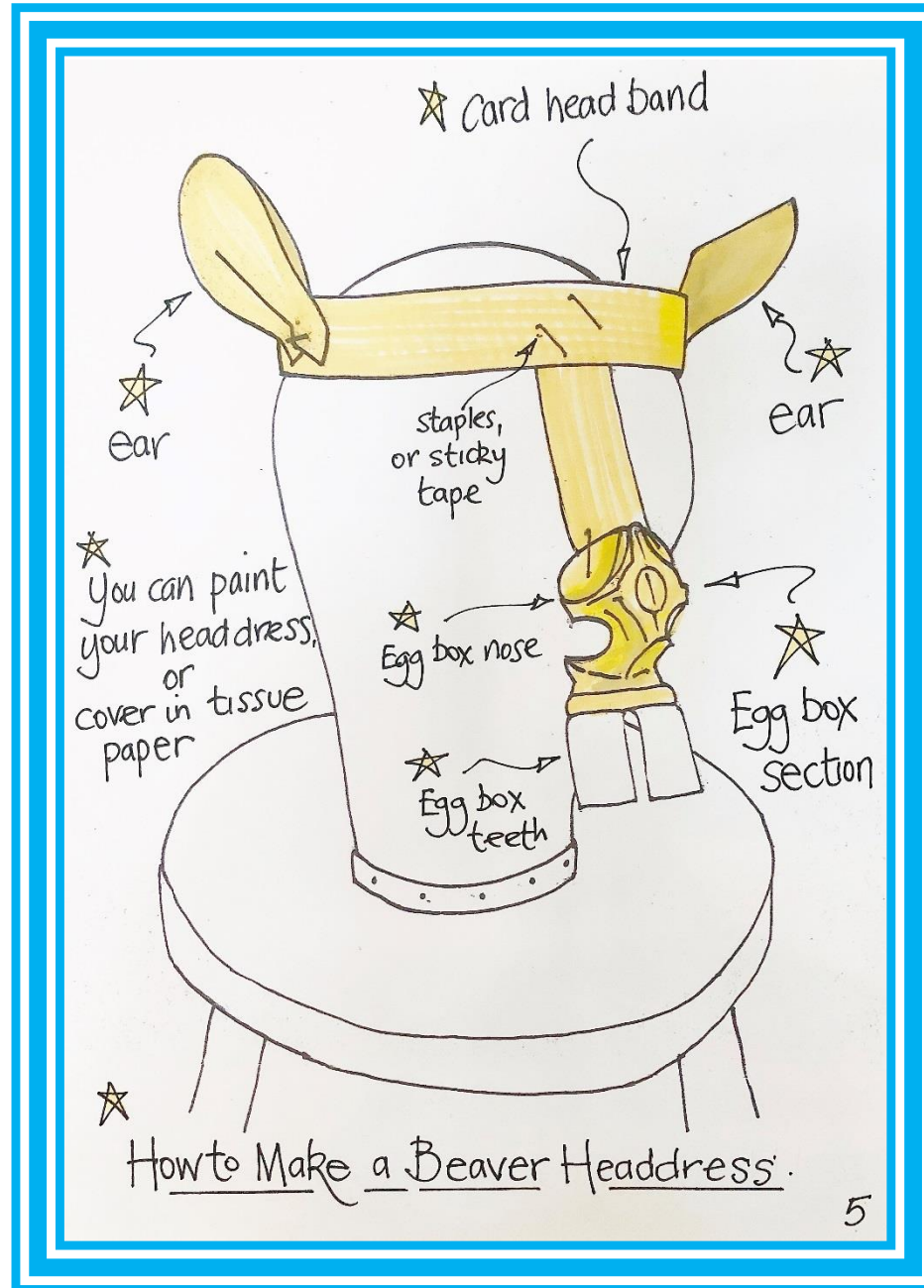

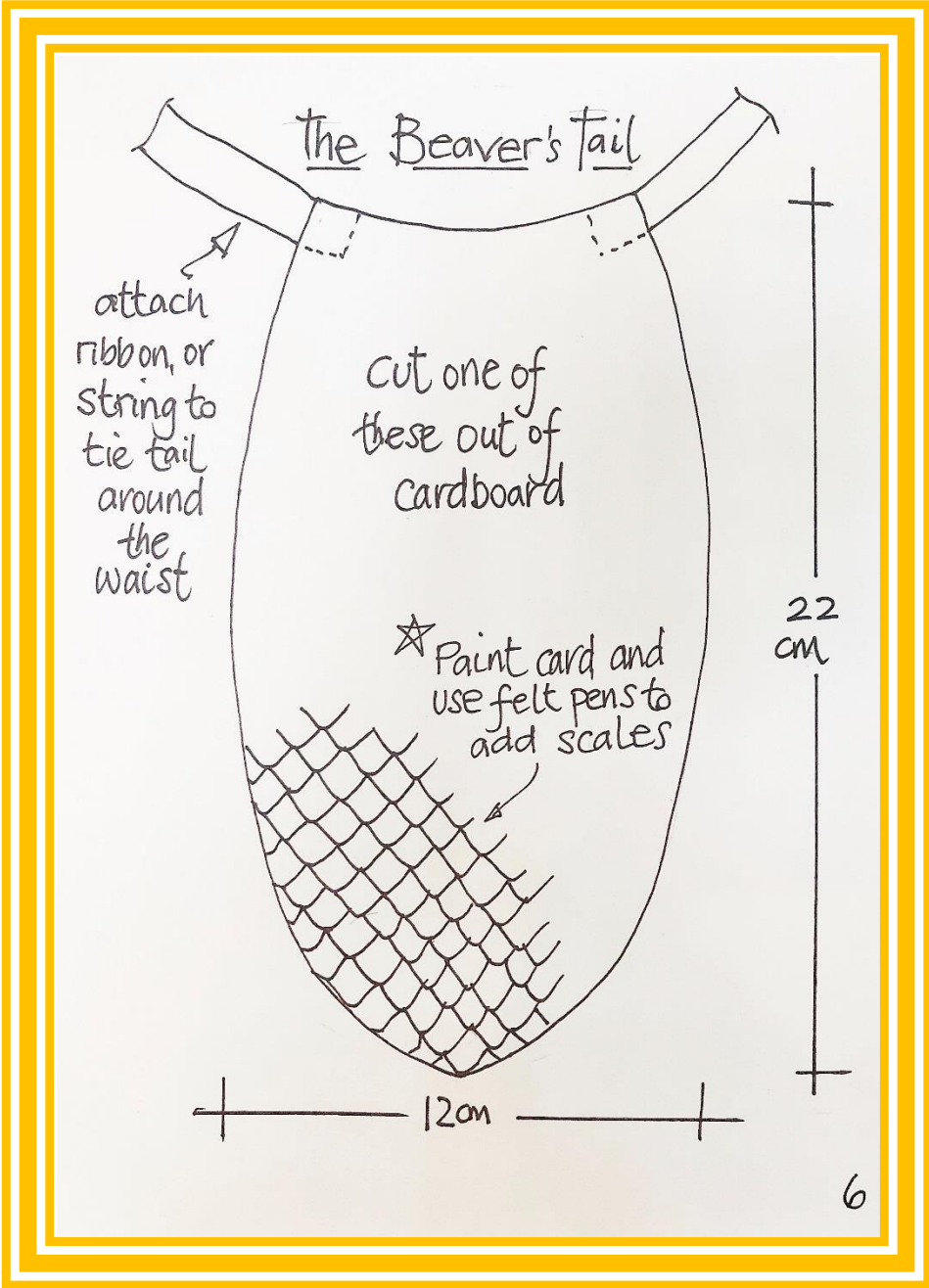





# How to Make a tree

- ★ Take a sheet of newspaper.
- ★ Get the biggest one

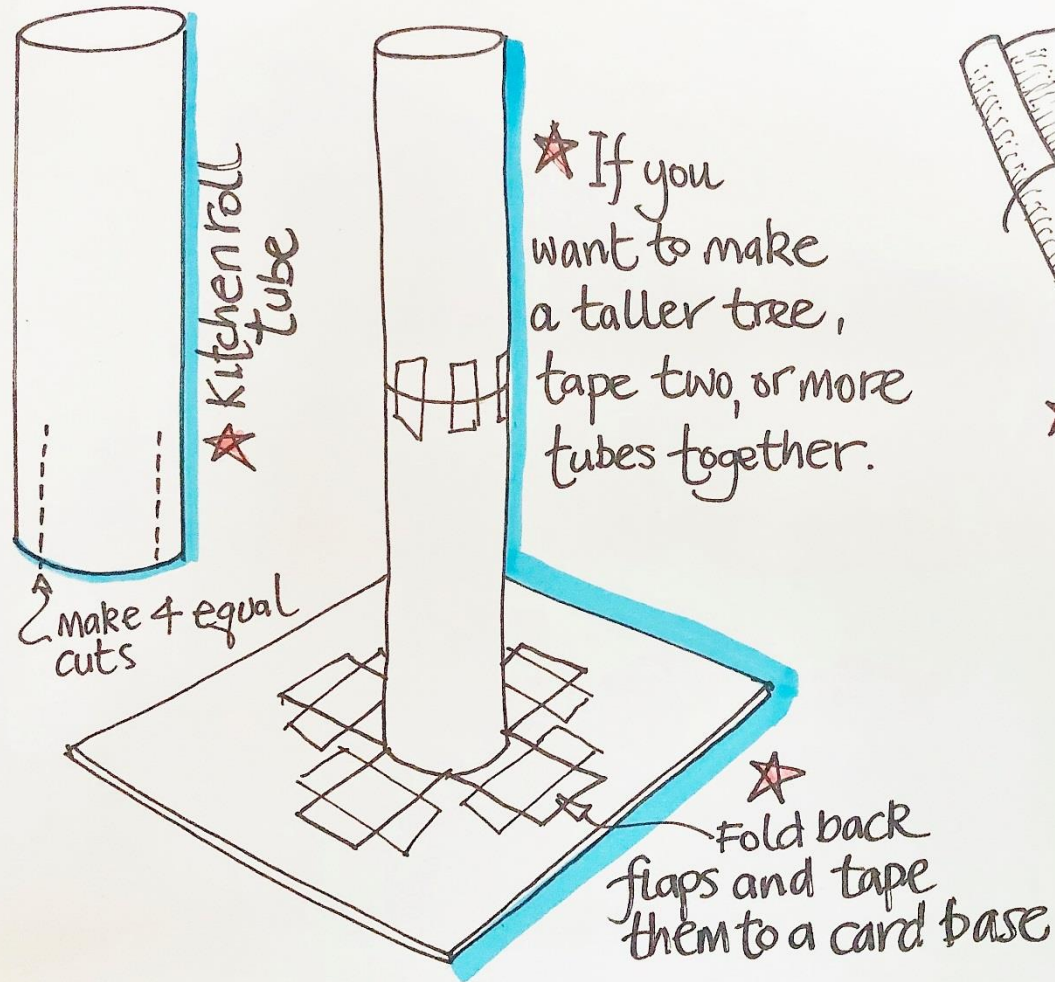

- ★ Roll up the sheet and fix at the bottom of one end with sticky tape

- ★ Use one sheet for each branch!



# How to Make a tree (continued)

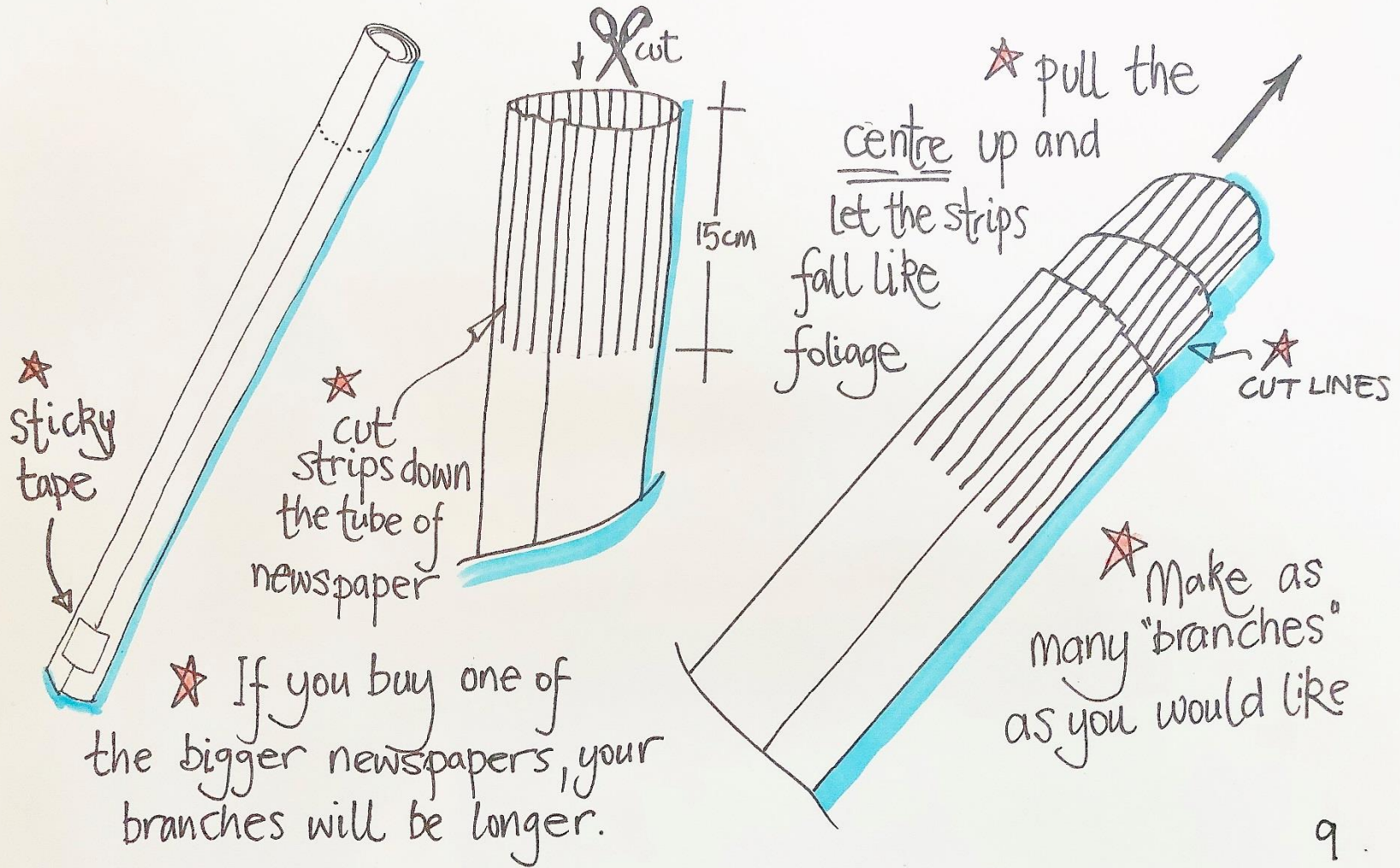

# How to Make a tree (continued)

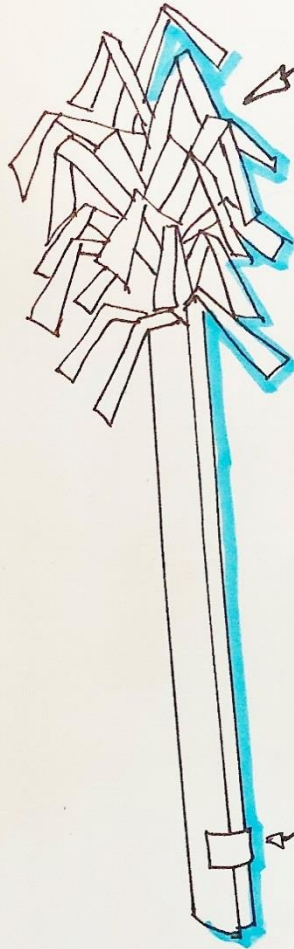

★ cut top when it's pulled up.

★ STICKY TAPE

★ Make as many branches as you would like and sticky tape them together.

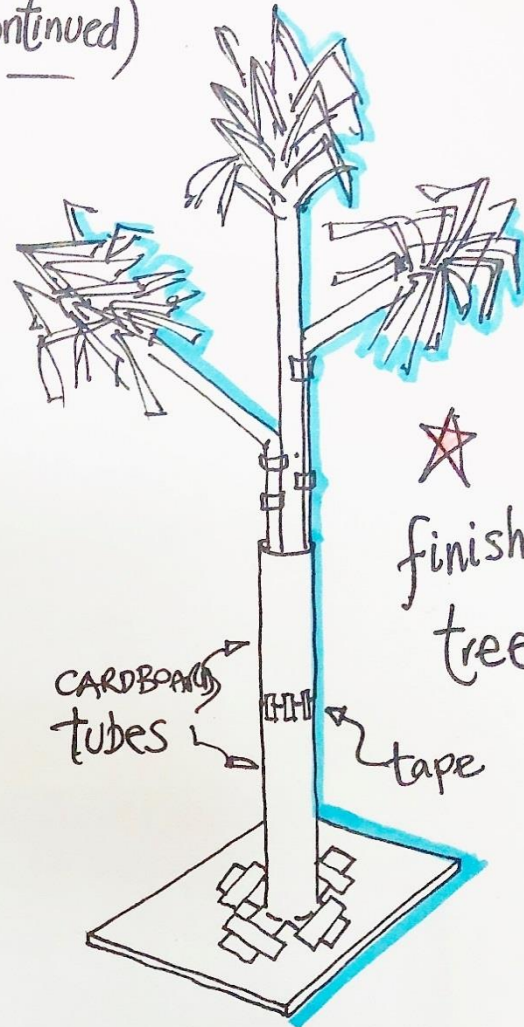

★ finished tree



## The Beaver's Dam

- ★ Use a small table - maybe a picnic table if you have one - with two small chairs leaning against it.

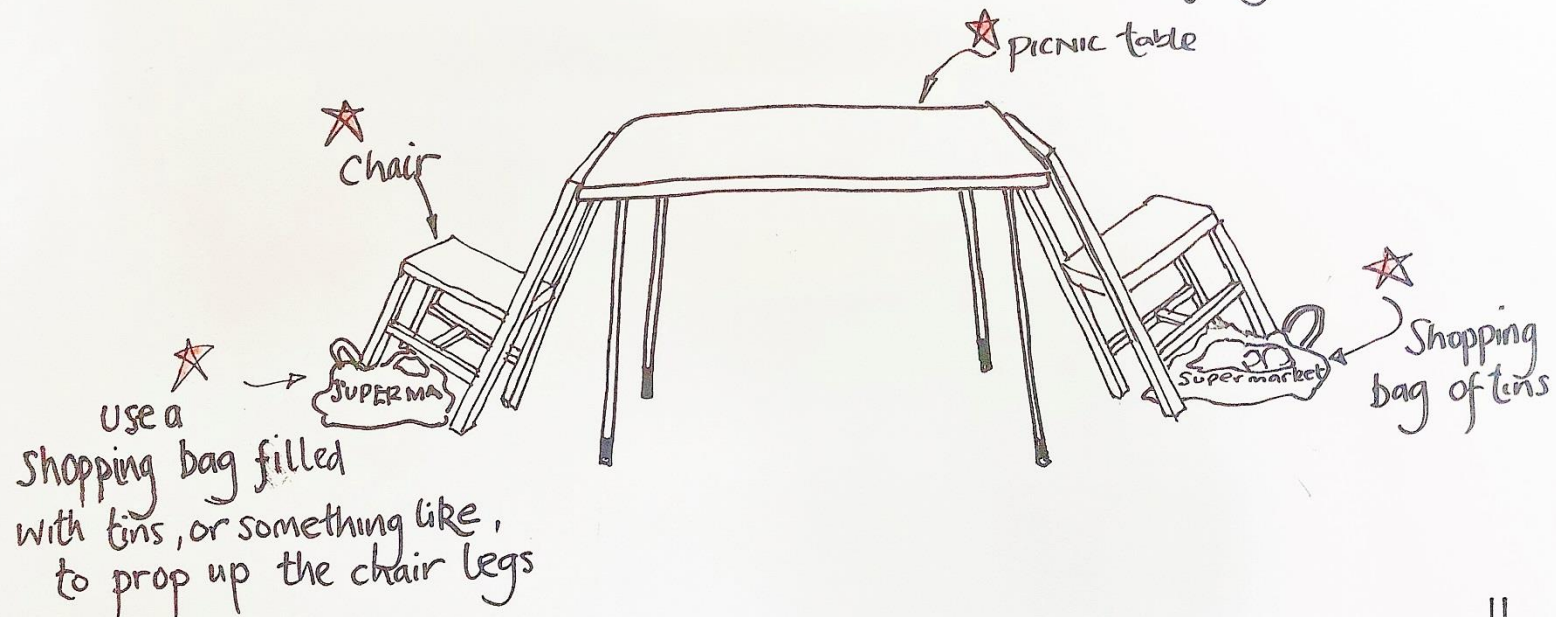

## Make your Backcloth from a sheet

★ Make stars out of cardboard and cover with tin foil

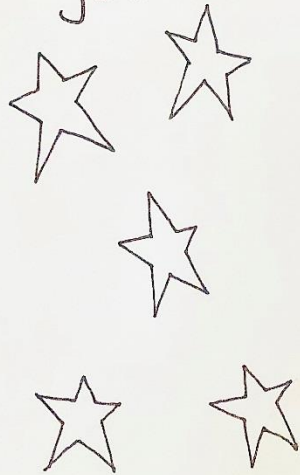

fix stars to sheet with safety pins

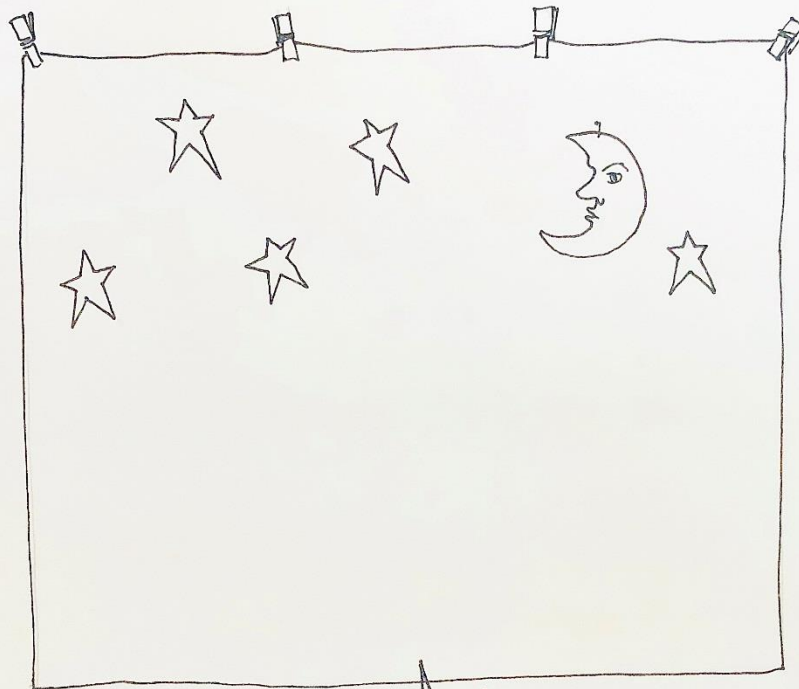

★ Make a Moon face out of card and paint it white. Draw details on with felt pens

★ If you have one, use a blue sheet pegged to the back line



# The Beaver's Dam

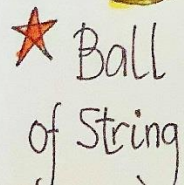
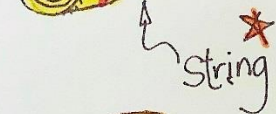

★ Newspaper  
branches —  
see other  
sheet

★ sheet  
covers table  
and chairs

★ Rolled up towels of lots of sizes,  
tied with string, make the logs that form  
the Beaver's Dam



Now you're ready to go!

Here's the story and song to perform on your stage...

## To Be A Beaver

STAN THE BEAVER: Oh Morag, I'm exhausted. We'll never fell this tree.

MORAG THE BEAVER: Of course we will...

STAN THE BEAVER: And get the whole dam rebuilt before dawn?

MORAG THE BEAVER: We're brilliant at building dams.

STAN THE BEAVER: But what's the point? Someone will only come and destroy it again. Face it - no one likes us. Maybe we should just... give up.

MORAG THE BEAVER: Give up? Oh, Stan...







*Chorus*

*It's not easy to be a beaver  
Or a human being either  
We deserve a chance, everybody does  
Surely there is hope for all of us.*

*Verse 1*

*Even when we're down  
We've reasons to be proud  
We're beautiful my dear  
And quite the engineers*





*At the swimming baths  
We're all top of the class  
In backstroke and front crawl  
No one comes close at all*

*Our giant teeth alone  
Stay sharp all on their own  
If we had bigger paws  
I'd burst into applause...*

*But we can praise our kind  
By using our behinds  
Our special tails can slap  
The river just like that  
If only all the humans knew that - !*





*Chorus*

*It's not easy to be a beaver  
Or a human being either  
We deserve a chance, everybody does  
Surely there is hope for all of us.*

*Verse 2*

*Some people on the land  
Don't really understand that  
We'd love a quiet life  
Like other wildlife*





*We've come from other nations  
There are some complications...*

*But we never interfered  
A human put us here*

*The River Tay is long  
It's Scotland's longest one!  
There's lots to go around and  
It's where we've all been found*

*We didn't have a choice  
But now we have a voice  
We're using it to say  
It would be nice to stay...  
And live forever on the Tay! 'Cause-*



*Chorus*



*It's not easy to be a beaver*

*Or a human being either*

*We deserve a chance, everybody does*

*Surely there is hope for all of us.*

*Bridge*

*So what do beavers bring?*

*Well here's a brilliant thing*

*When we construct a home*

*It isn't ours alone*

*We do our job so well*

*That rivers start to swell*

*And other plants and animals all come to live as well!*





*Chorus*

*It's not easy to be a beaver*

*Or a human being either*

*We deserve a chance, everybody does*

*Surely there is hope for all of us.*

*We deserve a chance, everybody does*

*Surely there is hope for all of us.*



STAN THE BEAVER: It's not such a big tree, really. We'll have this done in no time.

MORAG THE BEAVER: You know, Stan... some of the humans actually quite admire us Beavers.

STAN THE BEAVER: How do you figure that out, then?

MORAG THE BEAVER: Well, when a human is very enthusiastic to get to work on something -

STAN THE BEAVER: Yeah?

MORAG THE BEAVER: And they show a real commitment to it -

STAN THE BEAVER: Mm?



MORAG THE BEAVER: Well, then the humans point at them and say  
'Oh! You're an eager semi-aquatic rodent, aren't you?'

STAN THE BEAVER: They're a funny bunch, the humans...

MORAG THE BEAVER: I've always thought so.

THE END







Produced by Pitlochry Festival Theatre September 2020  
Port Na Craig Pitlochry Perthshire PH16 5DR | Tel: 01796 484626 | [BoxOffice@pitlochryfestivaltheatre.com](mailto:BoxOffice@pitlochryfestivaltheatre.com)  
[www.pitlochryfestivaltheatre.com](http://www.pitlochryfestivaltheatre.com)